

MARCO[®]

FLUID TECH

**SELF-PRIMING ELECTRIC PUMP
FOR TRANSFERRING VARIOUS LIQUIDS**

INSTRUCTIONS FOR USE

164 660 15-US - UP2/E 12/24V

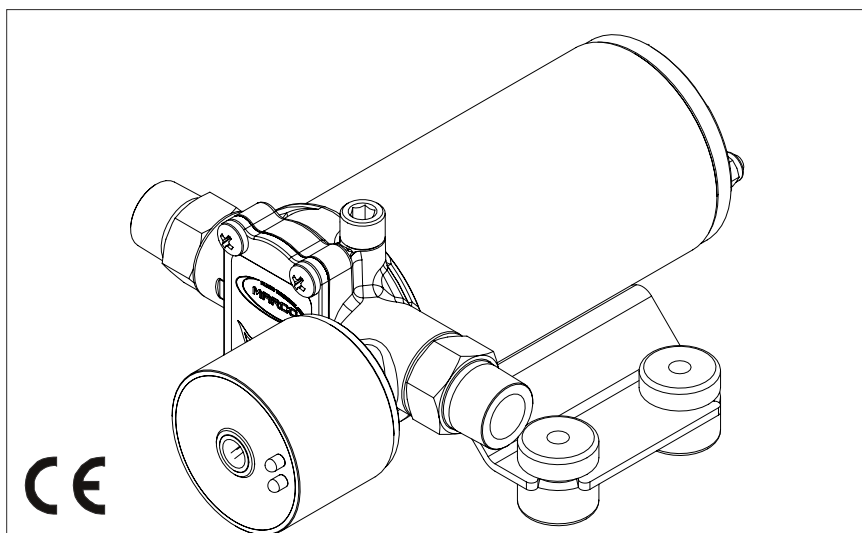

11/09/18 Rev.05

AIR VENT VALVE ACTIVATION

When starting the pump, or when emptying the tank, slightly open the small valve, in order to let the air out and facilitate the priming.

As soon as the pump is operating close the small valve.

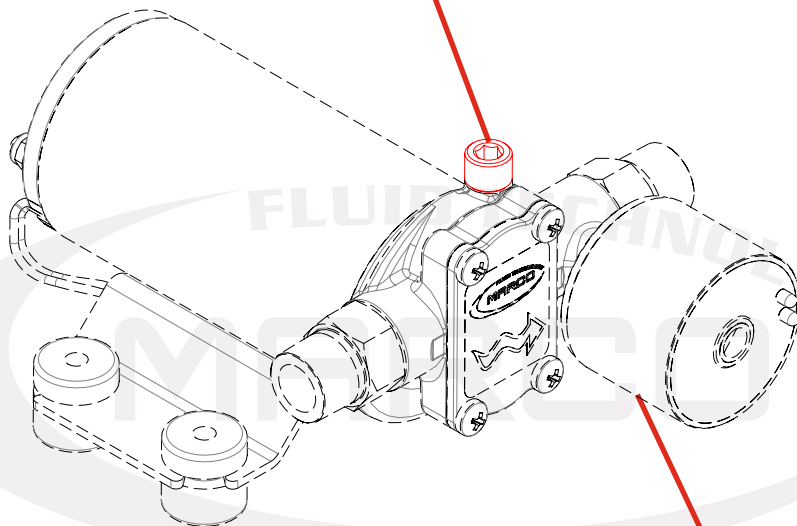

ELECTRONIC PRESSURE SENSOR

ELECTRONIC PRESSURE SENSOR WORKING DIRECTIONS

The electronic pressure sensor, through the use of a microprocessor, controls the pump's speed to obtain the needed flow rate, with the following advantages:

- Noise reduction during operation
- The optimization of current consumption
- A strong reduction of electrical noise, thanks to the slow speed ramp up and ramp down of the motor.
- A longer life for the whole system, thanks to less wear of pump parts compared to conventional mechanical pressure switches.

The pressure sensor system is equipped with two LEDs: one blue and one multicolored (red, green, and yellow).

During normal operation, the blue LED will:

- Turn on if there's liquid in the hoses.
- Turn off when there's no liquid in the hoses.
- Flash when in priming mode. The first time it senses water it keeps flashing for 10 seconds to make sure that the water is being pumped correctly and continuously.

If the pump goes more than five times from "priming" to "no liquid" (blue led off) the circuit turns everything off anyway, to protect the motor and the gears from running without liquid.

The multicolored LED signals:

- With solid yellow LED, that the pressure in the hoses is not the required pressure, but the pump is trying to reach it.
- With solid green LED, that the pump has reached the target pressure, there is still liquid demand, but the pump's speed won't be changed because the flow rate is constant.
- With flashing green LED, the pump has reached the target pressure and there is no liquid demand, it's in stand-by with the motor off.
- With solid or slowly flashing red LED, the motor has been short circuited, something may have blocked the gears or there could be a problem in the connection between the pump and circuit. The red LED flashes for 30 seconds, after which the pump is re-fed up to a maximum of 3 attempts.

On the fourth attempt, the LED remains solid red, the pump is off and should be checked for possible permanent damage.

To reset this warning you need to reboot the circuit or press the Reset button on the control panel, if present.

(follows)

- With fast flashing red LED, the pump is being overloaded (due to viscous liquids or gears overheating). While the pump is running, the speed is reduced to keep the current up to the nominal value for 30 seconds, period after which the circuit tries to release again the motor to its normal operating speed.

If an overload happens again, the circuit tries three times to lower the speed and it turns the pump off. Please check that the liquid being pumped is correct for the chosen pump and that the gears move freely without problems.

To reset this warning you have to reboot the circuit or press the Reset button on the control panel, if present.

There are two warnings that use both LEDs:

- Red and blue LED that blink alternatively, signal that the pump has run one and a half minute without liquid and the motor has been stopped for this reason. To reset this warning you have to reboot the circuit or press the Reset button on the control panel, if present.
- Yellow and blue LED that blink together indicate that the power supply is providing the wrong voltage. Please check to have the correct wire section for the power supply and a charged battery, if present.
- Steady red and blinking Blue indicate that the pump has run for more than two hours at very low speeds and that the motor has been stopped to prevent overheating. To reset this warning you have to reboot the circuit or press the Reset button on the control panel, if present.

WARNINGS

An expansion tank of at least ½ liter is necessary in the case of short, rigid pipes or in the presence of solenoid valves, to avoid overpressures during the closing phase caused by a water hammer effect which could damage the pressure sensor.

The presence of a few meters of flexible pipe inside the system can prevent the installation of the expansion tank.

Additional pressure regulators or non-return valves on the pump delivery may interfere with the correct operation of the electronic pressure sensor.

PRODUCT DESCRIPTION

A

Self-priming gear pump, integrated check valve and electronic pressure sensor: to be used as automatic pump for boats, trucks, camper, etc.

Nichel-plated brass body, PTFE gears, stainless-steel shaft and lip seal.

The electronic pressure sensor is preset at 2 bar - 29 psi.

TECHNICAL DETAILS

B

CODE	TYPE	VOLT	FUSE	FLOW RATE	PRESSURE	WEIGHT	P.CS x CART.
164 660 15	UP2/E	12/24	7.5 A	2.6 gpm	29 psi	2.8 lb	12

AMBIENT CONDITIONS

C

TEMPERATURE: min.-10°C 14°F-max.60°C 140°F **RELATIVE HUMIDITY:** max. 90 %

 **WARNING:** the above indicated temperature ranges are applicable to all components of the pump and these limits must be respected in order to avoid any possible damage or malfunctioning.

OPERATING CYCLE

D

The pump has been designed for discontinuous use. Under conditions of high operating pressures (eg. with closed or blocked outlet, excessive length of the delivery circuit and/or excessive pressure due to accessories), it can be subjected to elevated stresses and overheating and therefore should not be used for prolonged periods under such conditions.

APPLICATIONS

E

There are numerous fields of applications for the pump, however only exclusively with the allowed liquids mentioned:

- Main use as automatic pump for freshwater and sanitary water systems on boats, camper.

F FLUIDS ALLOWED / NOT ALLOWED

ALLOWED:

FRESH WATER AND SEA WATER (max 40 °C-104 °F)

NOT ALLOWED:

- PETROL (GASOLINE)
- FLAMMABLE LIQUIDS with PM < 100 °F
- LIQUIDS WITH VISCOSITY > 20 cSt
- FOODSTUFF LIQUIDS
- CORROSIVE CHEMICAL PRODUCTS

- SOLVENTS

RELATED DANGERS

- FIRE EXPLOSION
- FIRE EXPLOSION
- MOTOR OVERHEATING
- FOODSTUFF LIQUID CONTAMINATION
- PUMP CORROSION
- INJURY TO PERSONNEL
- FIRE EXPLOSION
- DAMAGE TO SEALS

WARRANTY EXPIRES IF MAX FLUID TEMPERATURE IS EXCEEDED

G TRANSPORTATION AND HANDLING

Due to limited weight and dimensions the pump does not require the use of any special handling or lifting equipment. When handling manually, normal personal protective gear should be worn (safety shoes with toe piece, etc.)

The pump is carefully packed prior to shipment. Upon receiving, the packaging should be inspected for damages and the pump stored in a dry area.

H INSTALLATION

It is recommended that the use of the pump be according to normative safety standards and also as per the precautions listed below.

H-1 PRELIMINARY CHECKS

Check that there has been no damage to the pump during transportation or storage. Both inlet and outlet ports should be carefully cleaned removing possible dust or residual packaging material. Verify that the available electrical power supply corresponds to the specification requirements.

H-2 POSITIONING

The pump can be mounted in any position. Fix it utilizing suitable screws corresponding to the antivibration mounts supplied.

⚠ WARNING: THE MOTOR IS NOT EXPLOSION PROOF. Do not install the pump where flammable vapours or gases may be present. Install it in an accessible place for inspection.

The pump is IP55 protection rated. It is good practice to avoid any pump contact with water splashes possibly causing water seepage into the motor with high risk of internal oxidation and/or short circuit.

TUBING CONNECTIONS

H-3

- Prior to making any tube/hose connections, check that the inlet ports have no end caps;
- Do not position the pump at a excessive height with respect to the minimum level of the fluid to be transferred. Damage may occur if this height is exceeded as the pump may not draw fluid. Make sure that the outlet tube is empty and without chokes;
- Avoid choking the inlet or outlet tubes so that efficiency is optimized.
- The use of an inlet filter is recommended especially with fluids containing impurities (mesh ASTM no. 35). In this case frequent cleaning and maintenance of the filter is advisable. The standard filter withstands a maximum positive pressure of 0.5 bar.
- Utilize tubes and connection pieces that are resistant to the fluid types handled and avoid any possible environmental dispersion.

The electrical installation must include a protection fuse which is suitably rated as indicated on the motor label and sized with reference to the chosen point of application.

WARRANTY EXPIRES IF NO FUSE IS UTILIZED

Always mount the anti vibration rubber fittings supplied with the pump kit. Their usage ensures a consistent reduction in noise and vibration levels.
Electrical cabling size should depend on the distance between pump and battery power supply.

Up to 6.6 ft length: AWG 18.

The use of undersized cabling can cause overheating of the electrical wiring and subsequent fire hazard. There will also be a voltage drop at the motor terminals with a consequent reduction in efficiency.

The flow rate value indicated on the motor label is obtained with a 13 mm-1/2 in, internal tube diameter. Tubes with inferior diameters will cause an increase in current with potential risk of motor overheating. On the outlet side it is advisable to use at least a short section flexible tubing.

To ensure the correct directional flow of the fluid as indicated by the arrow on the top plate, it is necessary to connect the positive pole (+) of the battery supply to the red wire on the motor end-cap and the negative pole (-) to the black wire. Electrical connections must be made using adequate terminal blocks and connectors ensuring a tight fitment of the electrical cables. Bad wiring can cause power losses and/or overheating of the cabling itself.

 **WARNING:** it is the responsibility of the installation technician to ensure a correctly designed circuit installation fitted according to ABYC regulations. Environmental risks must be taken into account with the installation.

I TROUBLESHOOTING

I-1 CHECK POINTS IF THE PUMP HAS STOPPED OR WILL NOT START

- Check the effectiveness of the battery power supply (voltage activity);
- Check if the fuse has blown;
- Check for any foreign matter present in-between the pump gear drives. To do this, disconnect the power supply and unscrew the four fixing screws, remove the front cover plate and inspect the chamber. Replace the cover plate in the same initial position after inspection;
- Avoid running the pump dry for more than a few minutes. Pumps found defective that have run dry in the absence of fluid are not covered by warranty;
- The average life span of the motor commutator brushes is approximately 1000 hours under normal operating conditions. Stoppages are possible due to brush wear and tear after such a time period.

I-2 WHY THE PUMP WILL NOT PRIME ITSELF?

- The pump is fitted at a height greater than 1,5 m - 4,9 ft above the fluid level;
- The pump has run dry for too long a period;
- Long periods of inactivity. In this case it is advisable to add liquid directly into the chamber before start-up. It is also advisable to add, before running the pump, a drop of lubricating oil inside the pump only;
- Air leak at the suction pipe due to the following reasons:
possible cuts in the pipe, inadequate hose clamps, malfunctioning of the filter due to defective/worn seals or filter clogged;
- Air leak at the front plate cover due to the following reasons:
Loose fixing screws, poor effectiveness of the seal;
- Faulty electrical cable connections;
- Presence of obstructions or restrictions in the suction or delivery pipes or the use of special devices(eg. automatic spray pistol or aqua-stop);
- Presence of liquid loops in the outlet tube.

I-3 GOOD PRACTICES ENSURING A WELL FUNCTIONING PUMP

No particular maintenance is required if the pump is utilized for the transfer of diesel fluids. If it is expected that the pump will not be used for a period of at least 30 days, especially in the case of usage with fresh or salty water, it is advisable to run fresh water through it and to then loosen the front plate screws. Upon re-use, run the pump briefly (a few seconds) and tighten the screws again. Check under conditions of maximum operating pressure that the motor current value is within the motor label specifications.

NORMAL MAINTENANCE

I-4

- Check frequently and keep the inlet filter clean;
- Check every month the chamber and keep clean from any foreign matter;
- Check every month that electrical wiring is in good condition;

INDICATORS THAT THE PUMP IS FUNCTIONING CORRECTLY

I-5

- Temperature of body and motor frame is within 140°F-158°F;
- Regular flow and constant noise levels;
- Amp-draw within the limits indicated in the technical details.

TO OPEN THE PUMP

I-6

It is recommended that a specialized service technician be consulted for any repair work or the replacement of worn out internal components, exclusively with original spare parts; During the warranty period, only by authorized Marco S.p.A. personnel, failing which the warranty will expire.

ENVIRONMENTAL DISPOSAL

L

Do not dispose of pumps into household waste: pumps that are no longer usable, must be collected separately and disposed of in an environmentally correct manner.

PACKAGING ENVIRONMENTAL DISPOSAL

L-1

The user is invited to effect a proper waste separation, in order to facilitate the recycling of the materials of which the packing is composed.

WARRANTY

M

1. The Warranty period is 2 years from date of purchase on production of the appropriate sales invoice.
2. Should the original sales invoice not be available, then the 2 year warranty period will be valid from production date.
3. The Warranty becomes null and void in the case of incorrect utilization or disregard of the instructions contained herein.
4. The Warranty only covers original production defects.
5. The Warranty does not cover any related installation costs involved.
6. Transport costs are refundable only in the case where warranty has been duly accepted by Marco Spa and they will be limited to the actual shipment costs between Marco Spa warehouse and the client's delivery address.
7. No credit notes or replacement items will be issued prior to the receipt and proper testing of any Marco goods that are deemed faulty.

EXPLODED VIEW

Pos.	Q.ty	Description
1	1	PUMP BODY
2	1	SEAL
3	2	ROD
4	1	PUMP FRAME
5	1	BRUSH HOLDER
6	1	COMPENSATION SPRING
7	2	BALL BEARING
8	1	ARMATURE
9	2	WASHER
10	2	NUT
11	1	IDLE GEAR
12	1	KEY

Pos.	Q.ty	Description
13	1	DRIVING GEAR
14	1	O-RING
15	1	TOP PLATE
16	4	SCREW
17	1	NON RETURN VALVE
18	1	ELECTRONIC PRESSUR SENSOR
19	1	O-RING
20	1	AIR VENT CAP
21	2	NIPPLE
22	2	O-RING
23	4	ANTIVIBRATION MOUNT

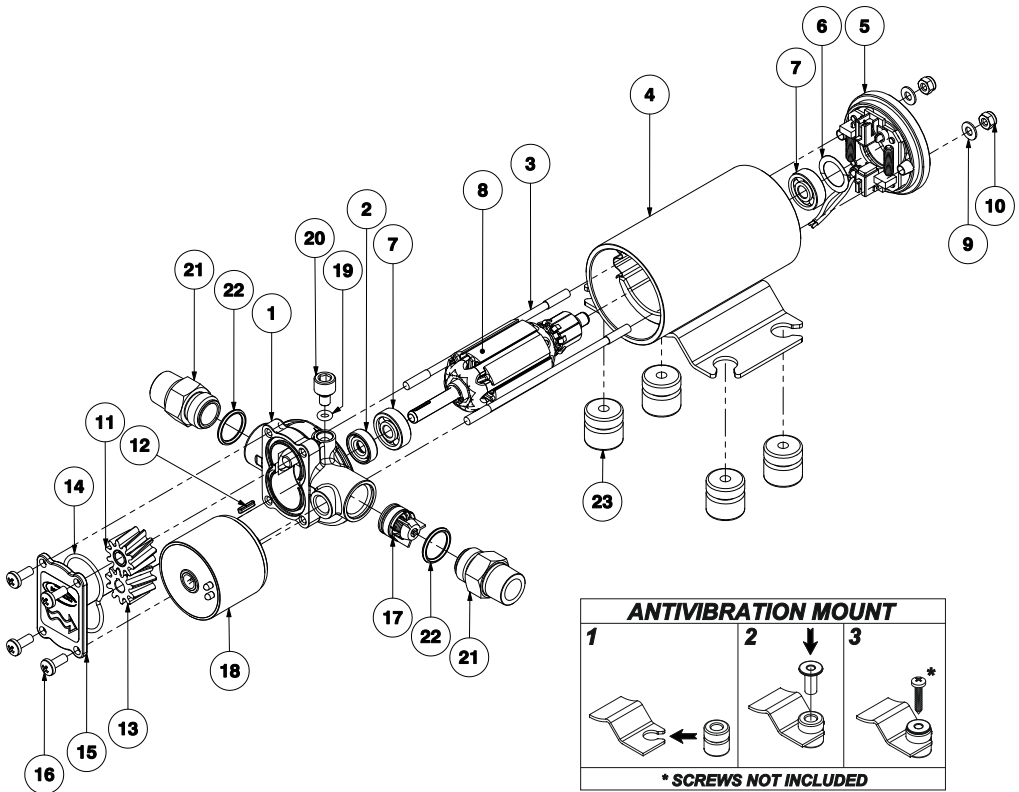

DIMENSIONS

○

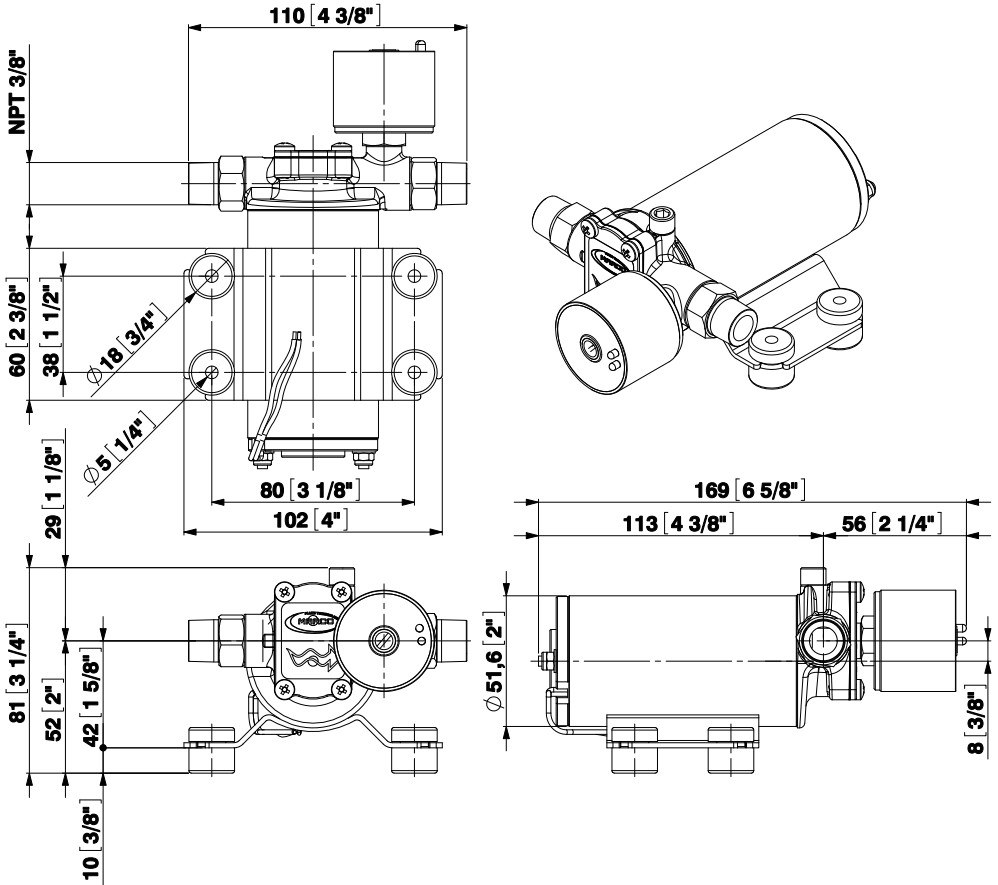

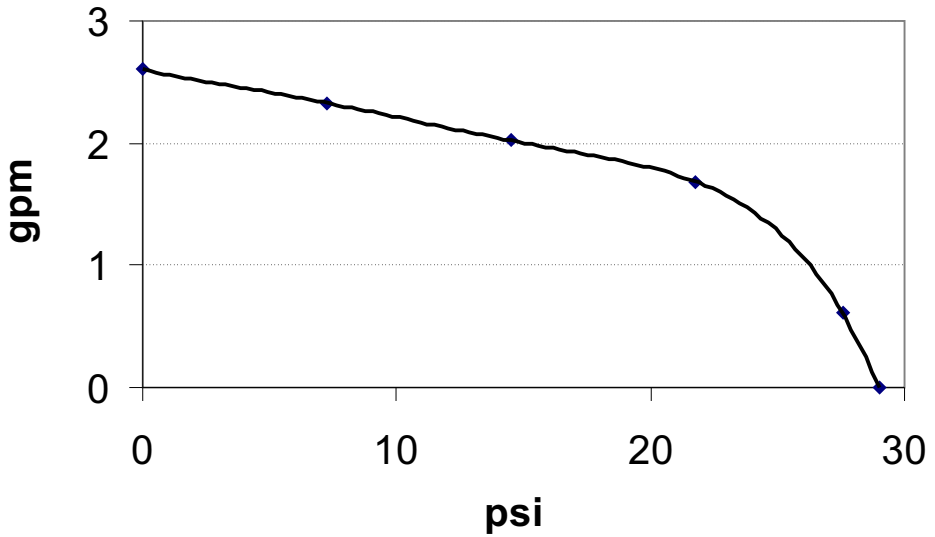
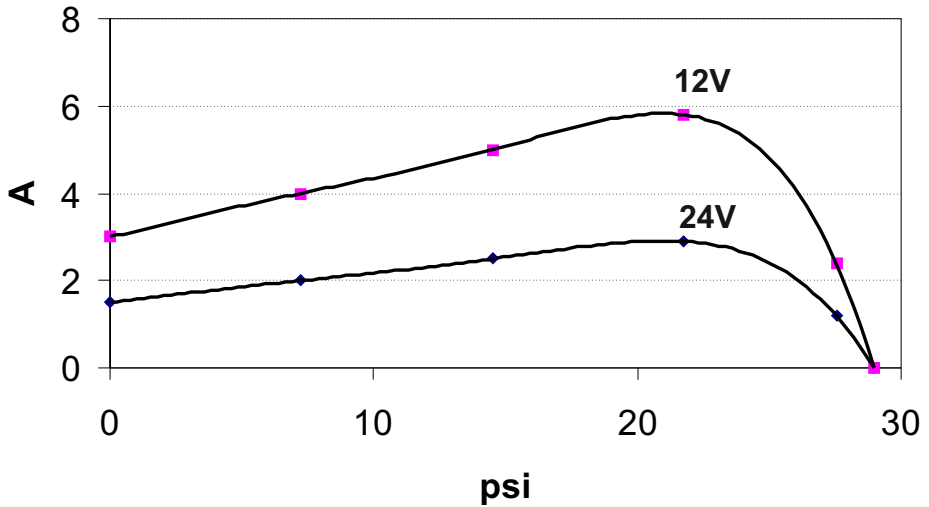
FLOW RATE DIAGRAM*AMPERE-DRAW DIAGRAM*



E.C. DECLARATION OF CONFORMITY

We confirm that the product:

164 660 15 - UP2E 12/24V Electronic Gear pump

is in conformity with the Directive 2014/30/EU (ex. 2004/108/EC) relating to electromagnetic compatibility and with the Directive 2006/42/EC relating to the machines.

This declaration is valid for all products which are produced in accordance with the technical documentation which is a part of this declaration. For verification of conformity with regard to the Electromagnetic Compatibility the following standards are applied:

EN 55014-1

Electromagnetic compatibility,
Requirements for household appliances,
electric tools, and similar apparatus.
Part 1: Emission.

EN 55014-2

Electromagnetic compatibility,
Requirements for household appliances,
electric tools, and similar apparatus.
Part 2: Immunity.

This declaration is given under the sole responsibility of:

MARCO S.P.A.
Via Mameli 10 - 25014 Castenedolo - Brescia - Italy
Tel. 030/2134.1 Fax 030/2134.300

Property of MARCO S.p.A reproduction prohibited. All rights reserved.

For further information visit our web site - www.marco.it

Marco S.p.A Via Mameli 10 - 25014 Castenedolo (Brescia) – Italy

tel. +39 030 2134.1 / Fax +39 030 2134.300